

assignment of dissociative water exchange on $\text{Ga}(\text{H}_2\text{O})_6^{3+}$ provides the evidence necessary to show that gradual changeover in substitution mechanism, from associative to dissociative interchange, across the period of the first-row trivalent high-spin transition-metal ions already observed in nonaqueous solvents⁶ is also operative in water.

Estimations of the rate constant and activation volume for water exchange on $\text{Ga}(\text{H}_2\text{O})_5\text{OH}^{2+}$ indicate that this species is much more reactive and has more dissociative character than the hexaqua ion, as is the case for other pairs of trivalent hexaqua and monohydroxy pentaqua ions.

Acknowledgment. This work was financially supported by the Swiss National Science Foundation (Grant No. 2.854-0.85).

Registry No. $\text{Ga}(\text{H}_2\text{O})_6^{3+}$, 19521-89-2; $\text{Ga}(\text{H}_2\text{O})_5\text{OH}^{2+}$, 12519-06-1; H_2O , 7732-18-5.

Supplementary Material Available: Temperature and pressure dependence of transverse relaxation rates (Tables S1 and S2), correlation coefficient matrices of the computer fits (Tables S3 and S4), and kinetic and quadrupolar contributions to the transverse relaxation rates (Table S5) (11 pages). Ordering information is given on any current masthead page.

Theoretical Study of the Cyclopropane Ring Opening by Palladium(II) Complexes

Margareta R. A. Blomberg,*† Per E. M. Siegbahn,† and Jan-Erling Bäckvall†

Contribution from the Institute of Theoretical Physics, University of Stockholm, S-113 46 Stockholm, Sweden, and the Department of Organic Chemistry, Royal Institute of Technology, S-100 44 Stockholm, Sweden. Received November 19, 1986

Abstract: CASSCF and contracted CI calculations have been performed on the ring opening of cyclopropane by different palladium(II) compounds (PdCl_2 , PdCl_4^{2-} , and PdCl^+). Two reaction mechanisms were studied, corner activation and edge activation. The results are compared to a previous study of the reaction of the ligand-free palladium(0) atom with cyclopropane, and, as expected, it was found that the addition of the chloride ligands changes the reaction barriers drastically. For palladium(0) only the edge activation has a low activation energy. For the palladium(II) complexes only the corner activation by PdCl^+ has a low activation energy, estimated to be about 5 kcal/mol. For PdCl_2 and PdCl_4^{2-} very high barriers (25–45 kcal/mol) are found for both corner and edge activation. The energy differences between the complexes investigated are found to be directly related to the excitation energies of the atomic states of palladium involved. The atomic state of palladium involved in a complex is determined by the actual number of covalent bonds, and the actual charge of palladium. The atomic state is reflected in the calculated 4d population of palladium. The results obtained in this paper lead to a new view on the ring opening of cyclopropane by palladium(II): corner activation, rather than the usually accepted edge activation, is predicted to be the most favorable reaction pathway.

I. Introduction

The interaction between transition metals and small strained-ring hydrocarbons often leads to the cleavage of one of the C–C bonds. In recent experimental studies of chloropalladation of the cyclopropane ring in (+)-2-carene, two different products were obtained.¹ The two products have different stereochemistry at the active carbons, and different C–C bonds have been cleaved. It was proposed¹ that the main difference in the reaction mechanisms leading to the two products is that one of them involves a corner activation of the cyclopropane ring by palladium (see Scheme I, reaction A) and the other an edge activation (see Scheme I, reaction B). The results from this experimental study inspired the present theoretical investigation of the edge and the corner mechanisms for the activation of cyclopropane by palladium(II) complexes.

In a previous theoretical paper² the corner and the edge palladation of cyclopropane by palladium(0) were studied. However, most of the experimentally studied cyclopropane ring-opening reactions involving platinum metals were performed with palladium(II) and platinum(II). The purpose of the present paper is therefore to perform a similar theoretical study on palladium(II). In the above mentioned experimental study¹ of chloropalladation of cyclopropane the reactant was $\text{PdCl}_2(\text{MeCN})_2$, and it is natural to use PdCl_2 as a model for palladium(II) complexes. This complex yields high barriers for both the edge and the corner

Scheme I. Ring Opening of Cyclopropane by Palladium

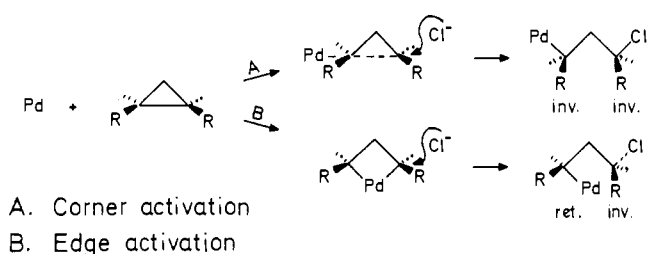

mechanism of the cyclopropane ring opening. Two other complexes, PdCl_4^{2-} and PdCl^+ , which are both present in a solution of the PdCl_2 polymer were therefore also investigated.

Our goal has been to estimate reaction barriers for the two reaction mechanisms for cyclopropane ring opening, and for this purpose we have calculated the most interesting parts of the potential energy surfaces. The activated complex between cyclopropane and the metal is different for the two reaction mechanisms. In the case of corner activation the activated complex has a biradical structure, and in the case of edge activation the

(1) (a) Ahmad, M.; Bäckvall, J. E.; Nordberg, R. E.; Norin, T.; Strömberg, S. *J. Chem. Soc., Chem. Commun.* 1982, 321. (b) Bäckvall, J. E.; Björkman, E. E. *Ibid.* 1982, 693. (c) Wilhelm, D.; Bäckvall, J. E.; Nordberg, R.; Norin, T. *Organometallics* 1985, 4, 1296.

(2) Bäckvall, J. E.; Björkman, E. E.; Pettersson, L.; Siegbahn, P.; Strich, A. *J. Am. Chem. Soc.* 1985, 107, 7408.

*University of Stockholm.

†Royal Institute of Technology.

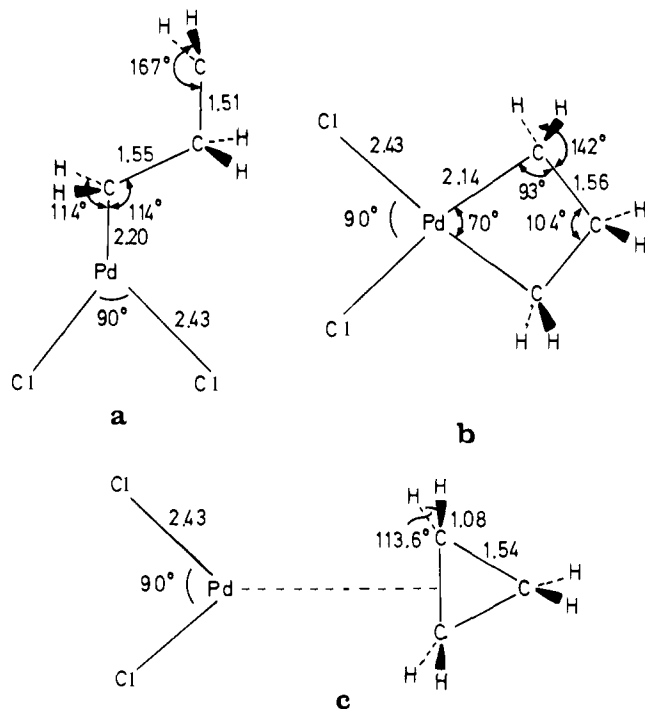

Figure 1. Geometries used for (a) the biradical after corner attack, (b) palladacyclobutane after edge attack, and (c) cyclopropane and palladium complex at long distance. The PdC_3H_6 geometries are taken from ref 2, and the chlorine ligand conformation is varied in the calculations as described in the text (distances in angstroms).

activated complex is a metallacyclobutane. We have calculated the energy of these two activated complexes relative to free cyclopropane with the palladium chloride complex at far distance. In the previous study on palladium(0) the geometries of the activated complexes were optimized, and to simplify the calculations we use the same PdC_3H_6 geometries in the present study.

Perhaps surprisingly, very different reaction barriers are found for different palladium(II) complexes. We will show how these results can be explained through a simple analysis of the wave functions. A very useful characteristic of a transition metal in a complex is the sum of the actual number of covalent bonds and the actual charge on the metal. We further show that the total number of covalent bonds formed by palladium determines the atomic states which have to be involved. The excitation energies of the different atomic states, in turn, determine the relative thermodynamic stability of complexes with different numbers of covalent bonds.

As for the palladium(0) study, we have performed MCSCF calculations to obtain a qualitatively correct description of the bond-breaking process. To obtain a higher accuracy for the interaction energies we have also included dynamic correlation by means of CI calculations, which is generally found to be very important for chemical reactions, particularly those involving transition metals. In the following section we give a description of the calculations, and in section III the resulting potential surfaces and the characteristics of the wave functions are described. The results are summarized and discussed in sections IV and V.

II. Details of Calculations

Complete active space self-consistent field (CASSCF) and contracted configuration interaction (CCI) calculations were performed for certain parts of the potential surfaces of $\text{Cl}_2\text{PdC}_3\text{H}_6$, $\text{Cl}_4\text{PdC}_3\text{H}_6^{2-}$, and $\text{ClPdC}_3\text{H}_6^+$. The Gaussian basis sets used were of double ζ quality plus a diffuse d function on palladium. For Pd and Cl the inner-shell electrons were replaced by an effective core potential (ECP). Below we describe the geometries of the complexes, the details of the CASSCF and CCI wave functions, and finally the basis sets.

(a) **Geometries.** Four different parts of the potential surfaces were investigated: (1) the biradical structure obtained after a

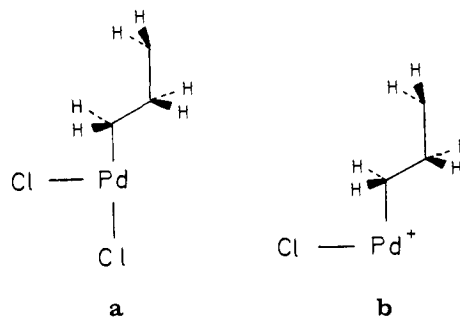

Figure 2. Optimal ligand conformations for the biradical after corner attack of (a) PdCl_2 and (b) PdCl^+ .

corner attack (Figure 1a), (2) the palladacyclobutane complex obtained after an edge attack (Figure 1b), (3) cyclopropane with the palladium chloride complexes at long distance (Figure 1c), and (4) an intermediate structure between the previous two, taken from the transition-state geometry of the edge attack in the $\text{Pd}(0)$ reaction.²

The geometry of the PdC_3H_6 part of the complexes was for each of these four structures taken from the previous study on $\text{Pd}(0)$.² These geometries are shown in Figure 1 for the $\text{Cl}_2\text{PdC}_3\text{H}_6$ case. Figure 1 also shows the initial structure of the chloride ligands for $\text{Cl}_2\text{PdC}_3\text{H}_6$. In the $\text{ClPdC}_3\text{H}_6^+$ case the single chloride ligand was first placed on the bisector of the two Pd-Cl bonds shown in the figure. In $\text{Cl}_4\text{PdC}_3\text{H}_6^{2-}$ the two extra chloride ligands were placed out of plane to form a pseudooctahedral structure.

Some variations in the orientation of the chloride ligands were performed, and the resulting optimal structures are sketched in Figure 2, in the cases where they deviate from those described in the previous section. For the biradical and palladacyclobutane structure of $\text{Cl}_2\text{PdC}_3\text{H}_6$ the two chloride ligands were rotated 90° out of the PdC_3 plane, and for the biradical structure also an in-plane 45° rotation of the ligands was performed, producing the T-shaped structure of Figure 2a. For the biradical form of $\text{ClPdC}_3\text{H}_6^+$ the chloride ligand was rotated in the PdC_3 plane to give the structure shown in Figure 2b. For the free PdCl_2 also the linear structure was studied. For the free PdCl_4^{2-} the square-planar structure and a tetrahedral structure were compared to the frozen ligand structure from the combined $\text{Cl}_4\text{PdC}_3\text{H}_6^{2-}$ complex.

In all the calculations reported a Pd-Cl distance of 2.43 \AA ($4.60 a_0$) was used, which is close to the Pd-Cl distance optimized in a previous study on PdCl_2 .³ The Pd-Cl distance was optimized in the palladacyclobutane form of ClPd , and a somewhat longer distance was obtained, 2.54 \AA ($4.80 a_0$), but the energy changed by only 2 kcal/mol, and the original distance was therefore kept throughout this study.

(b) **Methods.** The CASSCF method⁴ was used to incorporate the effects of near degeneracy in the description of the potential surfaces. When chemical reactions are studied the active space has to be chosen to include all orbitals involved in the breaking and forming of bonds, which in this case means bonding and antibonding orbitals of the Pd-C bonds, one C-C bond in cyclopropane, and in some cases Pd-Cl bonds. In some cases also the Cl lone-pair orbitals pointing toward Pd were correlated in the CASSCF calculations. To obtain reasonable interaction energies at the CASSCF level it is important that the CASSCF wave function has essentially the same quality at all parts of the potential surface, which sometimes forces the inclusion of some additional orbitals in the active space at certain points. The actual active spaces used are described for each case below in section IIc. The CASSCF calculations are described by sets of numbers: $(i, j, k, \dots / r, s, t, \dots)$, where i, j, k, \dots are the number of inactive orbitals in each irreducible representation and r, s, t, \dots are the number of active

(3) Bäckvall, J. E.; Björkman, E. E.; Pettersson, L.; Siegbahn, P. J. *Am. Chem. Soc.* **1985**, *107*, 7265.

(4) Siegbahn, P. E. M.; Almlöf, J.; Heiberg, A.; Roos, B. O. *J. Chem. Phys.* **1981**, *74*, 2384.

orbitals. The frozen inner-shell orbitals are not included in these numbers. The symmetry used in the calculations is C_{2v} , except for the biradical form which has only C_s symmetry.

To obtain a higher accuracy for the interaction energies, dynamic electron correlation was included in the wave function through configuration interaction (CI). The CI wave functions comprise all configurations obtained from single and double excitations out of a set of reference configurations. The reference states were chosen as those configurations having a coefficient larger than a certain threshold in the CASSCF wave function. In the present case the threshold varied between 0.10 and 0.15. The reason thresholds larger than 0.10 were used in some cases was simply to keep the number of configurations down to a manageable size also in these cases. The loss of accuracy from using the larger thresholds is expected to be insignificant compared to other errors in the calculation. The number of correlated electrons ranged from 12 to 18 depending on the molecule, including the formally eight 4d electrons in Pd(II), two electrons from one of the C-C bonds in cyclopropane, and two lone-pair electrons, pointing toward Pd, in each Cl^- ligand. The externally contracted CI (CCI) method was used to determine the CI wave functions.⁵ All the CCI energies reported here include a Davidson correction⁶ analogue for the many reference case, as an estimate of the effect of including higher than double excitations.

(c) **Specification of the CASSCF and CCI Calculations.** $\text{Cl}_2\text{-PdC}_3\text{H}_6$. In the CASSCF calculation the inactive/active space was chosen as (6,4,4,3/4,4,0,0) for PdCl_2 and cyclopropane at long distance, for palladacyclobutane, and for the transition-state geometry. For palladacyclobutane these active orbitals correspond to a bonding and an antibonding orbital for each of the two Pd-C bonds plus two Cl lone pairs pointing toward Pd, each with a corresponding correlating orbital. At large distance the two Pd-Cl bonds were correlated together with one C-C bond and one palladium 4d orbital. For the biradical structure after the corner attack the equivalent orbital spaces were (10,7/8,0). Except for the Cl lone pairs this active space contains the Pd-C bond with an antibonding orbital and the two radical orbitals. In the CI calculation 14 electrons were correlated and five configurations were used as reference states, except for the palladacyclobutane case where four reference configurations were used.

$\text{Cl}_4\text{PdC}_3\text{H}_6^{2-}$. The active space was chosen in the same way as for $\text{Cl}_2\text{PdC}_3\text{H}_6$, except that the Cl lone pairs and their correlating orbitals were excluded, which yields the spaces (10,6,7,4/2,2,0,0) for both palladacyclobutane and for the separated system with the PdCl_4^{2-} geometry frozen from palladacyclobutane. In the CI calculations 18 electrons were correlated and four configurations were used as reference states for the palladacyclobutane form and three for the separated system. These calculations were performed both with and without two positive unit charges at a suitable distance to investigate the effects of the electrostatic field from counterions. It was found that the effect on the interaction energies of the field from the positive charges was very small, and therefore the structure of the free PdCl_4^{2-} complex was investigated without field. The above-mentioned frozen ligand structure was then compared to a square-planar structure, for which only one of the Pd-Cl bonding orbitals was correlated in the CASSCF calculation, leading to (8,5,3,3/0,2,0,0). In the CI calculations on the free PdCl_4^{2-} 16 electrons were correlated and three reference states were used for the pseudo-octahedral fragment and two for the square-planar structure.

$\text{ClPdC}_3\text{H}_6^+$. For the palladacyclobutane form the active space was chosen in the same way as for $\text{Cl}_2\text{PdC}_3\text{H}_6^{2-}$; i.e., only the Pd-C bonds were correlated, leading to (6,3,4,2/2,2,0,0). At long distance one C-C bond and the Pd-Cl bond were correlated, giving the inactive/active space (5,4,4,2/3,1,0,0). For the biradical formed after the corner attack the Pd-C bonding and antibonding orbitals were active together with the two radical orbitals, which

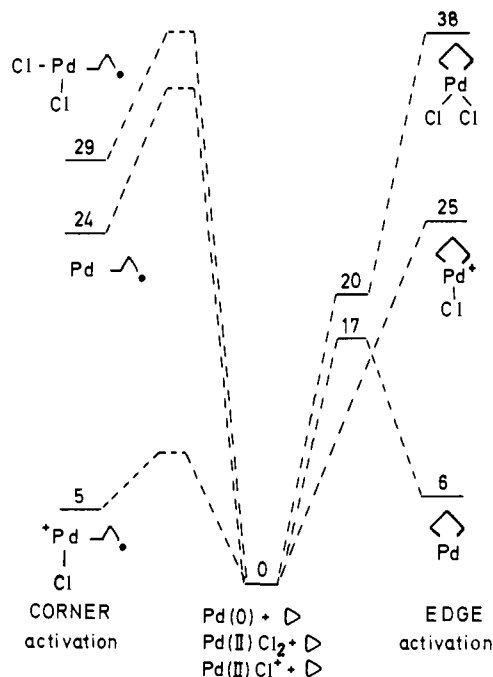

Figure 3. Calculated interaction energies in kcal/mol.

leads to (9,6/4,0). In the CI calculation 12 electrons were correlated. Three configurations were used as reference states at a large distance, six for palladacyclopropane and five for the biradical.

(d) **Basis Sets.** For carbon, hydrogen, and palladium the basis set from a previous study on the Pd(0) reaction² was used. The carbon basis is minimal basis contracted for 1s and double ζ contracted for the valence orbitals. The 1s core orbital was frozen in its atomic shape to avoid superposition errors. Hydrogen has a double ζ contracted s basis. For palladium a frozen core ECP⁷ was used, i.e., the innermost core orbitals (1s-3p) are parametrized in the potential, and the electrons in the outer-core orbitals (3d-4p) are explicitly treated, but the orbitals are frozen in their atomic shape. The basis set corresponding to the frozen orbitals is of minimal basis quality, and that corresponding to the valence orbitals is of double ζ quality with the usual augmentation of a diffuse d function (0.147). For chlorine the core orbitals (1s-2p) were replaced by an ECP, the 3s and 3p orbitals are described by a minimal basis contracted basis set,⁸ and a diffuse p function (0.058) is added.

III. Results and Discussion

In this section the corner and the edge activation of cyclopropane by palladium are compared. As expected it is found that the presently studied palladium(II) complexes behave differently from the previously studied palladium(0) complex. What is perhaps more surprising is that the different palladium(II) complexes behave quite differently from each other. In the case of palladium(0) the edge activation was found to be the most favorable one, and for the PdCl^+ the corner activation is most favorable. For PdCl_2 both reaction pathways have very high energy barriers. In the first part of this section the calculated energies are presented for each of the complexes treated.

The differences in energy between different complexes are best understood in terms of the involvement of excited atomic states of palladium, as reflected in the 4d populations obtained. Which atomic states are involved for a certain complex is determined by the number of covalent bonds and the actual charge on palladium. In the second part of this section the characteristics of the wave functions at the different parts of the potential surfaces

(5) Siegbahn, P. E. M.; *Int. J. Quantum Chem.* **1983**, *23*, 1869.

(6) Davidson, E. R. In *The World of Quantum Chemistry*; Daudel, R.; Pullman, B., Eds.; Reidel: Dordrecht, 1974.

(7) Pettersson, L.; Wahlgren, U.; Gropen, O. *Chem. Phys.* **1983**, *80*, 7.

(8) Broch-Mathisen, K.; Wahlgren, U.; Pettersson, L. G. M. *Chem. Phys. Lett.* **1984**, *104*, 336.

Table I. Calculated Interaction Energies for Various Palladium Complexes and Cyclopropane^a

| palladium complex | long distance | ΔE , kcal/mol | | |
|---------------------------------|---------------|---------------------------|----------------------------------|-----------------------|
| | | biradical (corner attack) | metallacyclobutane (edge attack) | edge transition state |
| Pd ^b | 0 | 24 | 6 | 17 |
| PdCl ₂ | 0 | 29.0 ^c | 37.5 | 19.8 ^e |
| PdCl ₄ ²⁻ | 0 | | 41.0 | |
| PdCl ⁺ | 0 | 4.6 ^d | 25.2 | |

^aCCI energies with the inclusion of a Davidson correction. ^bReference 2. ^cT-shaped PdCl₂C structure. ^dCl-Pd-C angle equal to 90°. ^eThe same geometry as for the transition state of the complex without ligands on palladium.

are described. The results for the palladium(0) reaction from ref 2 are also summarized here to simplify the comparisons.

(a) **Calculated Energies.** The calculated energies are summarized in Table I and Figure 3. The energy of cyclopropane and the palladium complexes at long distance from each other is taken as the reference energy in each case, and only energies relative to this conformation are reported. Relative energies are given for the biradical structure after a corner attack, for the palladacyclobutane structure after an edge attack, and finally for a structure with the same geometry as was obtained for the transition state after the edge activation by palladium(0). The PdC₃H₆ geometries are taken from the palladium(0) study, and the PdCl distance is kept fixed to 2.43 Å (4.60 a₀). Some variations in the orientation of the chloride ligands were performed, and the results from these variations are discussed in the text below. Only the CCI energies (including Davidson's correction) are reported, but the CASSCF energies give a very similar picture.

Pd(0) + C₃H₆. The results for this system were described in our previous study.² Palladacyclobutane is only 6 kcal/mol higher in energy than the palladium atom and cyclopropane at long distance. Because, as a rule, binding energies obtained in this type of approximation are too small, it is predicted that the system would have a positive binding energy in a more accurate treatment. A transition state was located for this reaction yielding a reaction barrier of 17 kcal/mol. The relative energy of the biradical structure obtained after a corner attack is 24 kcal/mol. The barrier for formation of the biradical was estimated to be about 10 kcal/mol further up in energy, i.e., at about 34 kcal/mol. The conclusion from these numbers is that the edge activation of cyclopropane is the preferred pathway for palladium(0) complexes.

Pd^{II}Cl₂ + C₃H₆. The effect of attaching two chloride ligands to palladium is a drastic increase in the energy of the palladacyclobutane structure to 37.5 kcal/mol, relative to the separated molecules. The transition state from the palladium(0) reaction has a relative energy of 19.8 kcal/mol; i.e., the reaction seems to be merely uphill. These energies were obtained for the ligand conformations shown in Figure 1. For the palladacyclobutane structure the chloride ligands were also twisted 90° to a plane perpendicular to the PdC₃ plane, but the energy was then raised even further to 41.9 kcal/mol. The biradical structure has a relative energy of 45.3 kcal/mol if the ligand conformation from Figure 1 is used. When the chloride ligands are twisted 90° out of the PdC₃ plane the energy is lowered to 35.7 kcal/mol, and an even lower energy of 29.0 kcal/mol is obtained for a 45° in-plane rotation of the chloride ligands yielding a T-shape of the Cl₂PdC fragment (see Figure 2a). As for the Pd(0) reaction,² the formation of the radical is estimated to have an additional barrier which was not calculated but is sketched in Figure 3. For the free PdCl₂ it was found that a linear structure is 7.4 kcal/mol higher than the structure with the two ligands in 90° angle. The conclusion from the numbers in this paragraph is thus that very high energies are needed for both the edge and the corner activation of cyclopropane by PdCl₂, and none of these reactions is very likely to occur at normal temperatures.

Pd^{II}Cl₄²⁻ + C₃H₆. In order to fulfill the 18-electron rule for palladium, two more chloride ligands were added. This addition should lead to a stabilization of the palladacyclobutane complex

and perhaps to a more favorable relative energy. The effect of the two extra Cl⁻ ligands is, however, very small; the interaction energy is raised from 37.5 kcal/mol for Cl₂PdC₃H₆ to 41.0 kcal/mol for Cl₄PdC₃H₆²⁻. The two new ligands were added opposite to each other out of the plane to give a nearly octahedral structure. For the free PdCl₄²⁻ complex a square-planar structure was found to be the lowest one, 47.5 kcal/mol lower than the frozen ligand structure from the combined complex. A tetrahedral structure was also tried for the free PdCl₄²⁻ but was outruled already at the CASSCF level, since it was very high in energy.

A technical comment should be made here, since the validity of a model with a negative charge could be questioned. The possible problem is that free negative ions in the gas phase often have a very diffuse wave function which has no counterpart in the experimental situation in a solution. To investigate this problem two positive charges mimicking counterions were introduced in the calculations. The energy difference between the combined and the separated complex (with the chloride ligands in a frozen structure) was calculated both with and without the positive charges. The effect of the positive charges on this energy difference was found to be small, about 5 kcal/mol, and it was concluded that the negative charge of the Cl₄PdC₃H₆²⁻ complex does not introduce large uncertainties in the calculations. This conclusion is further supported by the fact that the wave functions obtained with and without the positive charges are very similar. The electron affinity for the chlorine atom was calculated for the present basis set to be 2.63 eV at the SCF level, which should be compared to 2.5 eV obtained in an all-electron SCF calculation with a larger basis set.⁸ The experimental value is 3.83 eV.

Pd^{II}Cl⁺ + C₃H₆. Perhaps the most interesting result of the present study is that the biradical structure of ClPdC₃H₆⁺ is found to be only 4.6 kcal/mol higher in energy than the separated system. The presence of PdCl⁺ in a solution of PdCl₂ thus makes a corner activation of cyclopropane possible. Taking into account both the fact that calculated binding energies are usually too small and that a somewhat higher barrier probably has to be passed to reach the biradical structure, the total energy barrier for the corner activation of cyclopropane by PdCl⁺ is estimated to be only about 5 kcal/mol. The low energy for this biradical structure is obtained for a 90° angle between the Pd-Cl and the Pd-C bonds (Figure 2b). The energy is, however, not very sensitive to the position of the ligand. A linear Cl-Pd-C structure is only 4.4 kcal/mol higher in energy than the 90° angle conformation, and an intermediate structure is another 1.1 kcal/mol higher. The palladacyclobutane structure lies at 25.2 kcal/mol with the single chloride ligand oriented along the bisector of the two Pd-Cl bonds in Figure 1. It is thus concluded that PdCl⁺ can activate cyclopropane by the corner mechanism but not by the edge mechanism at normal temperatures.

(b) **Characteristics of the Wave Functions.** The oxidation number of a transition-metal atom in a complex is often associated with both a certain d population and a charge. For example, Pd(II) is considered to have a 4d⁸ population and a charge of +2. For the lower oxidation states the oxidation number is usually equal to the sum of the actual charge on the metal atom and the actual number of covalent bonds in the complex. It is only under such circumstances that the oxidation numbers will have chemical significance. For certain higher oxidation states the oxidation number tends to be larger than the sum of the charge and the number of covalent bonds. To understand some of the reaction mechanisms below, it will be important to realize this difference. Another important aspect of the present analysis we want to point out is the close correspondence between the atomic state of the transition metal and the maximum number of possible covalent bonds. A certain atomic state can only form as many covalent bonds as there are unpaired electrons (open shells). If palladium has two covalent bonds in a complex, there must be a significant involvement of the excited 4d⁹5s state, and if there are four bonds, the highly excited 4d⁸5s5p state, which is the lowest state with four open shells, must be involved. Through a simple analysis like this it is easy to understand that Pd(IV) compounds (with four covalent bonds) are much more rare than Pd(II) compounds.

Table II. Gross Atomic Populations (CASSCF Wave Functions) and Charge (q) for different Palladium Complexes Interacting with Cyclopropane

| Pd complex | Pd | | | | Cl ^a q | C ₃ H ₆ q |
|--------------------------------|------|------|-------|-------|------------------------|--------------------------------------|
| | 5s | 5p | 4d | q | | |
| long distance | | | | | | |
| Pd | 0.00 | 0.00 | 10.00 | 0 | | 0 |
| PdCl ₂ | 0.26 | 0.17 | 9.04 | +0.52 | -0.26 | 0 |
| PdCl ⁺ | 0.04 | 0.06 | 9.00 | +0.90 | +0.10 | 0 |
| biradical | | | | | | |
| Pd | 0.35 | 0.05 | 9.51 | +0.10 | | -0.10 |
| PdCl ₂ ^b | 0.30 | 0.24 | 8.99 | +0.47 | -0.30 | +0.14 |
| PdCl ⁺ ^c | 0.13 | 0.11 | 9.12 | +0.64 | +0.14 | +0.12 |
| palladacyclobutane | | | | | | |
| Pd | 0.57 | 0.08 | 9.23 | +0.13 | | -0.13 |
| PdCl ₂ | 0.39 | 0.44 | 8.57 | +0.59 | -0.46 | +0.32 |
| PdCl ⁺ | 0.27 | 0.33 | 8.57 | +0.84 | -0.43 | +0.59 |

^a Charge on each chlorine. ^b T-shaped PdCl₂C structure. ^c Cl-Pd-C angle equal to 90°.

As will be seen below it can also be understood why neither Pd(I) nor Pd(III) compounds have been observed.

When chloride ligands are attached to palladium the interaction with cyclopropane can be influenced in several ways. The ligands introduce a ligand field splitting of the d orbitals which simplifies covalent bonding in two ways. First, the excitation energy of the chemically more active states with lower 4d populations, e.g., the 4d⁹5s state, is lowered compared to the atomic 4d¹⁰ ground state. Further, the fact that certain 4d orbitals are pushed up in energy makes these orbitals more available for bonding to carbon since the overlap with the carbon valence orbitals is increased. An opposite effect of the chloride ligands, however, is to compete for the palladium bonding electrons, both in terms of forming covalent bonds with palladium and in terms of ionic interaction.

Below we describe the actual changes introduced in the biradical and the palladacyclobutane wave functions by the added chloride ligands, but first we discuss briefly the interactions between the ligands and the palladium atom. The results from the Mulliken population analysis are summarized in Table II.

Palladium Ligand Interaction. The bent PdCl₂ is formed by a 4d⁹5s configuration on palladium. The symmetric bonding orbital, involving the 5s electron on palladium, is essentially ionic in character, having 1.7 electrons on the chlorines. The antisymmetric bonding orbital is strictly covalent with one palladium 4d electron and one electron on the chlorines. The occupation numbers for the antisymmetric bonding and antibonding orbitals are 1.77 and 0.26, respectively. The high occupation of the antibonding orbital is typical for covalent bonds formed by d electrons in transition-metal complexes. The bent structure of PdCl₂ is a result of the sd hybridized bonds.

PdCl⁺ is formed by a 4d⁹ state of Pd⁺, and the covalent bond has one electron in a palladium 4d orbital and one electron on the chloride ligand. The occupation numbers of the bonding and antibonding orbitals are 1.59 and 0.40, respectively.

Biradical Structure. When one of the C-C bonds in cyclopropane is broken after a corner attack by a naked palladium atom a biradical is formed. One of the unpaired electrons remains at the γ carbon and the other one forms a covalent bond between the α carbon and palladium in the excited 4d⁹5s state, thus placing the second radical electron on palladium. In the PdC₃H₆ complex thus formed, palladium would be denoted as palladium(I). This biradical structure is very high in energy, which is expected for palladium(I) compounds for the following reason. To form one covalent bond the palladium atom has to be excited to a 4d⁹5s state, the same state as when two bonds are formed. When only one bond is formed the energy regained by the bonding is not enough to compensate for the excitation energy. Further, since palladium in this state is prepared to form two covalent bonds, it will be very reactive. These are the reasons why no palladium(I) compounds are known. The 4d population obtained for the biradical form of PdC₃H₆ is 9.5, and the actual wave function is thus a mixture between a 4d¹⁰ state and a 4d⁹5s state. Further, two delocalized orbitals with occupation numbers of about 1.4

and 0.6 are obtained rather than two localized radical orbitals.

All investigated structures of the biradical form of Cl₂PdC₃H₆ have high energies. The ligand orientation shown in Figure 1 has the highest energy, the wave function obtained has a Pd-C covalent bond and two Pd-Cl bonds, and the radical orbitals are located at the γ carbon and at the PdCl₂ moiety. This would be referred to as a palladium(III) compound, and a 4d⁸5s5p configuration is involved, which can be seen from the low 4d population (8.75). This wave function, however, has a very high energy, 45.3 kcal/mol, due to the high excitation energy to the 4d⁸5s5p state. Palladium(III) compounds are unstable for similar reasons as palladium(I) compounds, which were discussed above. For the other two structures of the Cl₂PdC₃H₆ complex, the T-shaped structure obtained after a 45° in-plane rotation of the ligands (Figure 2a) and the 90° out-of-plane rotation of the chloride ligands, the energy is somewhat lower, and a different type of wave function was obtained in the calculations. The PdCl₂ part of the wave function remains essentially the same as for free PdCl₂, and what would be expected to be the radical orbitals are instead a C-C bonding and a C-C antibonding orbital. Because the structure used has a very long C-C distance, the occupation numbers of the C-C bonding and antibonding orbitals are about 1.6 and 0.4. This complex has only two bonds (the Pd-Cl bonds), and a characterization as a palladium(III) compound would be misleading. The energies obtained for these two structures are still high and are a result of the unfavorable cyclopropane structure. An optimization of the geometry would, however, lead to two separated systems. The somewhat lower energy obtained for the T-shaped structure, 29.0 kcal/mol compared to 35.7 kcal/mol for the out-of-plane orientation, is probably due to a larger mixing of carbon character into the Pd-Cl bonds for the T-shaped structure. For the out-of-plane structure the antisymmetric bonding orbital can have no admixture of carbon bonding.

The low energy obtained for the biradical form of ClPdC₃H₆⁺, 4.6 kcal/mol, cannot be understood if the complex is classified, as it traditionally would be, as a palladium(III) compound. The highly excited 4d⁸5s state of Pd⁺ would then have to be involved, and the energy would be expected to be very high. Instead, the wave function obtained for the biradical shown in Figure 2b can be thought of as a mixture of two valence bond (VB) configurations, one to be characterized as ClPd⁺C₃H₆ and the other as Cl⁺PdC₃H₆. The sum of the actual number of covalent bonds and the actual charge of palladium is in both these configurations equal to 2. In the dominating VB configuration, ClPd⁺C₃H₆, the palladium ion is in its ground state, 4d⁹, and the interaction between palladium and chlorine has changed compared to long distance to a lone-pair interaction with a radical electron on chlorine in an orbital pointing away from palladium. A covalent Pd-C bond is formed with the unpaired 4d electron, and the second radical electron is located on the γ carbon. In the other VB configuration, Cl⁺PdC₃H₆, the positive charge is located on chlorine and palladium is in its lowest excited state, 4d⁹5s, and can form two covalent bonds, one to carbon and one to chlorine. The radical electrons have the same locations as in the first configuration. The resulting charge on chlorine is +0.14. The important features of these configurations are that palladium does not have to be excited to any of its higher states and that for each configuration palladium has as many covalent bonds as are optimal for the state involved. Further, by a mixing in of the Cl⁺PdC₃H₆ configuration it is possible to involve a configuration which binds to both carbon and chlorine. The 4d population, 9.12, shows that a d¹⁰ configuration is also involved. The wave function described is obtained for the 90° Cl-Pd-C structure. For the linear Cl-Pd-C structure a more complicated wave function is obtained. The palladium 4d population of 9.07, however, shows that mainly 4d⁹ configurations are involved, and there is also a large contribution of Pd-C bonding. The energy is, therefore, only slightly higher than that for the nonlinear structure.

A natural question now is whether the biradical form of Cl₂-PdC₃H₆ will have a similar mixing of VB configurations and thereby also obtain a low energy. The fact is that such a mixing does not occur. This can be understood from the fact that there

does not exist any low-lying VB configuration which can have three covalent bonds, i.e., which is binding to all ligands. For $\text{ClPdC}_3\text{H}_6^+$ one of the VB configurations is binding to all ligands.

Palladacyclobutane. In the palladacyclobutane form of PdC_3H_6 two covalent Pd–C bonds are formed. The symmetric bonding orbital involves the 5s electron on palladium, and the occupation numbers of the bonding and antibonding orbital are 1.90 and 0.05, respectively. The antisymmetric bonding orbital involves a 4d orbital on palladium, and the occupation numbers of the bonding and antibonding orbitals are 1.88 and 0.17, respectively. The total 4d population on palladium is 9.23, showing that the $4d^95s$ configuration is important. This complex can be characterized as a palladium(II) complex having two covalent bonds, and the energy is consequently low.

When two chloride ligands are attached to palladium the palladacyclobutane complex obtained after an edge attack is a palladium(IV) compounds with four chemical bonds, which thus must have a large involvement of the highly excited $4d^85s5p$ configuration (4d population 8.57). This is the reason why the interaction energy is raised from 6 kcal/mol for PdC_3H_6 to 37.5 kcal/mol for $\text{Cl}_2\text{PdC}_3\text{H}_6$. When two extra Cl^- ligands are added a very similar wave function is obtained, and the interaction energy is also similar, 41.0 kcal/mol for the palladacyclobutane form of $\text{Cl}_4\text{PdC}_3\text{H}_6^{2-}$. The palladacyclobutane form of $\text{ClPdC}_3\text{H}_6^+$ has three chemical bonds and the excited $4d^85s$ state of Pd^+ is involved, resulting in a 4d population of 8.57. The interaction energy is also in this case high, 25.2 kcal/mol. The symmetric Pd–C bonding orbital is formed from a 4d orbital on palladium, and the occupation numbers for these Pd–C bonding and antibonding orbitals are 1.7 and 0.3 for both $\text{Cl}_2\text{PdC}_3\text{H}_6$ and $\text{Cl}_4\text{PdC}_3\text{H}_6^{2-}$ and 1.8 and 0.2 for $\text{ClPdC}_3\text{H}_6^+$.

IV. Discussion

This study illustrates that a very useful characteristic of a transition-metal complex is the sum of the actual number of covalent bonds and the actual charge of the transition metal. This sum determines the atomic states which are involved in the wave function of a certain complex; e.g., a palladium compound with two covalent bonds and a neutral palladium involves the $4d^95s$ state and one with four bonds the $4d^85s5p$ state, which has four open shells. The excitation energies to the different excited states have a crucial influence on the relative stability of the different complexes, and the much higher energy of the $4d^85s5p$ state of palladium, compared to the $4d^95s$ state, explains why palladium compounds with four covalent bonds (oxidation state IV) are much less common than palladium compounds with two covalent bonds (oxidation state II). The traditional assignment of oxidation state to the metal in a complex is often equal to the sum of actual covalent bonds and charge of the metal, but this is not always the case. Very unfavorable oxidation states, like palladium(III), are in this study found to be "avoided", and the wave function actually obtained has a sum of the number of covalent bonds and charge which is less than the formal oxidation state. In this way the unexpected high stability of the biradical obtained after a corner attack on cyclopropane by PdCl^+ can be understood. The oxidation state III (which is the formal oxidation state) is for the biradical avoided by a mixing of a state with a neutral palladium with two covalent bonds and a state where palladium has one positive charge and one covalent bond. Both these latter states are otherwise typical for palladium(II) complexes.

In the present calculations, we have found a low activation energy for the corner attack on cyclopropane by only one of the investigated palladium(II) compounds: PdCl^+ . The edge activation barrier was found to be high for all the palladium(II) complexes studied. In a previous study it was shown that palladium(0) has a low energy for the edge-activated complex and a high energy for the corner-activated complex. The relative energies of all the complexes investigated can be fairly well understood from the type of analysis presented in the preceding paragraph, as is shown in section IIIb.

The fact that the calculations show a low energy path only for the corner activation by palladium(II) may seem contradictory

to the experimental results.^{1,13} For example, in the chloropalladation of (+)-2-carene (**1**) both an edge-activation and a corner-activation product was observed.¹ However, the calculated

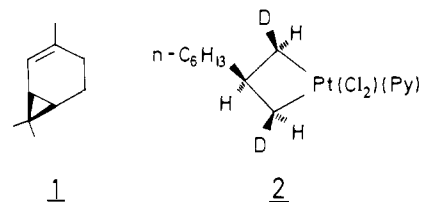

activation energy for edge attack is not unreasonably high, and the rest of the organic molecule outside the cyclopropane moiety may influence the reaction barrier. Since it is a vinylcyclopropane (+)-2-carene, the carbon–carbon bonds of the cyclopropane are, for example, expected to be weaker than those in free cyclopropane. Also, the solvent may influence the reaction barriers. It is interesting to note that raising the polarity of the solvent, which should favor formation of PdCl^+ , increased the relative amount of corner activation. Thus, in methanol or chloroform–ethanol the corner activation predominates. In a less polar solvent, such as benzene, the edge-activation pathway was favored by a factor of 6:1. In the latter solvent PdCl_2 is expected to be the main-reacting species. These experimental observations support the conclusion from the calculations that corner activation by palladium(II) is favored over edge activation only if a cationic palladium complex is formed.

In light of the high energy obtained for the palladacyclobutane $\text{Cl}_2\text{PdC}_3\text{H}_6$, which formally is a palladium(IV) complex, it is interesting to note that metallacyclobutanes of platinum(IV) have been observed.^{9–11} The formation of a platinum(IV) metallacyclopropane from a cyclopropane is considered to proceed via an edge activation (oxidative addition of the C–C bond), which has been established in one case by studying the stereochemistry of the process. Reaction of *cis*-2,3-dideuterio-1-*n*-hexylcyclopropane with $\text{PtCl}_2(\text{CH}_2=\text{CH}_2)$ followed by addition of pyridine afforded metallacyclobutane (**2**).¹¹ Platinum(IV) compounds are, however, expected to be more stable than palladium(IV) compounds since the excitation energy of the $5d^86s6p$ state in platinum is much lower than the corresponding excitation energy in palladium. Also, the 5d orbital in the platinum atom is higher in energy than the 4d orbital in the palladium atom, which will lead to a stabilization of the Pt–C bonds in platinumacyclobutane relative to the Pd–C bonds in palladacyclobutane.

Finally, the activation of cyclopropane by palladium complexes can be compared to the apparently similar process of corner and edge protonation of cyclopropane. The proton affinity of cyclopropane is very high. In a recent theoretical study¹³ the proton affinity of cyclopropane was calculated to be about 180 kcal/mol, and the difference between corner and edge protonation was very small, about 2 kcal/mol. Apparently the positively charged palladium complex behaves very differently from a proton in the interaction with cyclopropane.

V. Conclusion

The classical view of cyclopropane ring opening by transition metals has been that of an oxidative addition involving an edge activation. More recent stereochemical studies have shown that for palladium(II) also corner activation is a common pathway.^{1,14} Until now these corner activations have been considered to be a result of the special substrate used, and edge activation was still considered to be the more favored pathway.¹ The present cal-

(9) Gillard, R. D.; Keeton, M.; Mason, R.; Pilbrow, M. F.; Russell, D. R. *J. Organomet. Chem.* **1971**, *33*, 247.

(10) Yarrow, D. J.; Ibers, J. A.; Lenarda, M.; Graziani, M. *J. Organomet. Chem.* **1974**, *70*, 133.

(11) Dominelli, N.; Oehlschlager, A. C. *Can. J. Chem.* **1977**, *55*, 365.

(12) Albelo, G.; Rettig, M. F. *J. Am. Chem. Soc.* **1975**, *97*, 4510.

(13) Wiberg, K. B.; Kass, S. R. *J. Am. Chem. Soc.* **1985**, *107*, 988.

(14) Parra-Hake, M.; Rettig, M. F.; Wing, R. M.; Woolcock, J. C. *Organometallics* **1982**, *1*, 1478.

culations have led to a new understanding of the mechanism of cyclopropane ring openings by palladium(II), and it is found that exactly the opposite to what was previously thought is true. The conclusion is that corner activation is the favored pathway, especially when the metal has the possibility to ionize into a cationic complex. Instead it is the edge pathway that needs special cir-

cumstances to become available.

Acknowledgment. We thank Eva Björkman for her contribution to the calculations presented in this paper.

Registry No. C₃H₆, 75-19-4; PdCl₂, 7647-10-1; PdCl₄, 14349-67-8; PdCl⁺, 19651-81-1.

Rate Constant for Cyclization/Decyclization of the Phenyl Radical

M. J. S. Dewar,[†] W. C. Gardiner, Jr.,^{*†} M. Frenklach,[‡] and I. Oref[‡]

Contribution from the Department of Chemistry, University of Texas at Austin, Austin, Texas 78712, Department of Materials Science and Engineering, Pennsylvania State University, University Park, Pennsylvania 16802, and Department of Chemistry, Israel Institute of Technology—Technion, Haifa, Israel. Received November 18, 1986

Abstract: Formation of cyclic C₆H₅ from *CH=CH-CH=CH-C≡CH was investigated by means of the MINDO/3 parametrization of SCF-MO theory and RRKM calculations of the unimolecular rate constants for both directions of reaction.

We report a theoretical study of the formation of phenyl radical by attack of a terminal vinyl radical upon a terminal ethynyl group (Figure 1), a reaction of importance in soot nucleation.¹

Procedure

Structures and energies were computed by the MINDO/3 method with the MOPAC programs.² Standard MOPAC options were used for locating the transition structure³ and for computing force constants and vibrational frequencies. No constraints were used except for imposing planarity on the phenyl radical.

Rate constants for unimolecular isomerizations require an extension of standard RRKM theory.⁴ For incorporation into a modeling program the conversion from the open-chain radical (OC) to the phenyl radical (PR) has to be described by a kinetic equation

$$-\frac{d[\text{OC}]}{dt} = k_f[\text{OC}] - k_r[\text{PR}] \quad (1)$$

The corresponding formulation of the unimolecular process is written

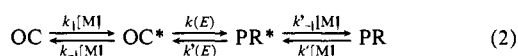

and the expression for k_f is

$$k_f = \int_{E_0}^{\infty} \frac{B(E)k(E) dE}{1 + \frac{k(E)}{k_{-1}[\text{M}]} + \frac{k'(E)}{k'_{-1}[\text{M}]}} \quad (3)$$

where $B(E)$ is the Boltzmann distribution of molecules and $k(E)$ is the RRKM energy dependent unimolecular rate constant.

Direct counts of densities and numbers of states were used for computing $k(E)$ from the MINDO/3 vibrational frequencies. The path degeneracy is 1 for isomerization of OC and 2 for isomerization of PR. Collision diameters were taken to be 0.53 nm for OC and PR and 0.34

Table I. Molecular Properties Computed by the MINDO/3 Method

| Hexa-1,3-dien-5-yn-yl radical | | | | | | | | |
|--|------|------|------|------|------|------|------|------|
| Standard Enthalpy of Formation: 116.8 kcal/mol | | | | | | | | |
| Moments of Inertia: ^a $A = 117.7$, $B = 356.6$, $C = 474.3$ | | | | | | | | |
| Vibration Frequencies ^b | | | | | | | | |
| 72 | 111 | 252 | 253 | 424 | 415 | 593 | 616 | 677 |
| 692 | 710 | 760 | 796 | 844 | 957 | 1089 | 1131 | 1184 |
| 1352 | 1584 | 1720 | 2311 | 3275 | 3421 | 3440 | 3640 | 3795 |
| Phenyl Radical | | | | | | | | |
| Standard Enthalpy of Formation: 69.6 kcal/mol | | | | | | | | |
| Moments of Inertia: $A = 134.9$, $B = 153.6$, $C = 288.4$ | | | | | | | | |
| Vibration Frequencies | | | | | | | | |
| 372 | 408 | 523 | 552 | 558 | 682 | 782 | 805 | 827 |
| 840 | 849 | 1031 | 1045 | 1089 | 1092 | 1152 | 1154 | 1238 |
| 1442 | 1457 | 1589 | 1686 | 3477 | 3484 | 3497 | 3518 | 3521 |
| Transition Structure | | | | | | | | |
| Standard Enthalpy of Formation: 133.4 kcal/mol | | | | | | | | |
| Moments of Inertia: $A = 149.6$, $B = 183.1$, $C = 332.7$ | | | | | | | | |
| Vibration Frequencies | | | | | | | | |
| -424 ^c | 230 | 301 | 308 | 440 | 462 | 613 | 666 | 682 |
| 717 | 750 | 765 | 823 | 866 | 1047 | 1080 | 1094 | 1171 |
| 1362 | 1456 | 1644 | 2057 | 3374 | 3475 | 3512 | 3582 | 3732 |

^aUnits g cm² × 10⁴⁰. ^bUnits cm⁻¹. ^cReaction coordinate.

nm for M, as estimates appropriate to reaction in Ar buffer gas; the corresponding collision diameter for PR-Ar and OC-Ar collisions is then

(1) Frenklach, M.; Clary, D. W.; Gardiner, W. C., Jr.; Stein, S. E. *20th Symposium (International) on Combustion*; The Combustion Institute: Pittsburgh, 1985; p 887. Frenklach, M.; Clary, D. W.; Gardiner, W. C., Jr.; Stein, S. E. *Shock Waves and Shock Tubes: Proceedings of the 15th International Symposium on Shock Waves and Shock Tubes*; Bershader, D., Hanson, R., Eds.; Stanford University Press, 1986; p 295. Frenklach, M.; Clary, D. W.; Yuan, T.; Gardiner, W. C., Jr.; Stein, S. E. *Combust. Sci. Tech.* **1986**, *50*, 79. Frenklach, M.; Clary, D. W.; Gardiner, W. C., Jr.; Stein, S. E. *21st Symposium (International) on Combustion*, in press.

(2) Bingham, R. C.; Dewar, M. J. S.; Lo, D. H. *J. Am. Chem. Soc.* **1975**, *97*, 1285, 1294, 1302, 1307. QCPE Publication 455, Department of Chemistry, Indiana University, Bloomington, Indiana 47405. Dewar, M. J. S.; Storch, D. M. *J. Am. Chem. Soc.* **1985**, *107*, 3898.

[†] University of Texas at Austin.

[‡] Pennsylvania State University.

[‡] Israel Institute of Technology—Technion.